

## FEATURES

- | High Density Cell Design For Low  $R_{DS(On)}$
- | Voltage Controlled Small Signal Switch
- | Rugged and Reliable
- | High Saturation Current Capability
- | ESD Protected

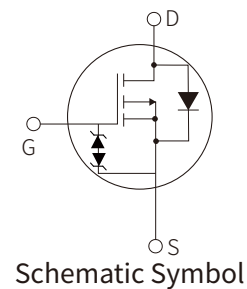
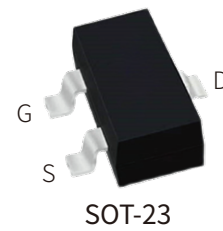

## APPLICATION

- | Direct logic-level interface: TTL/CMOS
- | Drivers: relays, solenoids, lamps
- | hammers, display, memories, etc.
- | Battery operated systems
- | Solid-state relays

## APPROVALS

<b>RoHS</b>	Compliance with 2011/65/EU
<b>HF</b>	Compliance with IEC61249-2-21:2003

## ABSOLUTE MAXIMUM RATINGS

Parameter	Conditions	Symbol	Value	Unit
Drain-Source Voltage	$T_A=25^\circ\text{C}$	$V_{DS}$	-20	V
Drain Current- Pulsed	$T_A=25^\circ\text{C}$	$V_{GS}$	$\pm 8$	V
Drain Current	$T_A=25^\circ\text{C}, V_{GS}=-4.5\text{V}$	$I_D^*$	-4	A
Pulsed Drain Current	$T_A=25^\circ\text{C}, V_{GS}=-4.5\text{V}$	$I_{DM}^{**}$	-16	A
Total Power Dissipation	$T_A=25^\circ\text{C}$	$P_{tot}$	0.83	W
	$T_A=100^\circ\text{C}$		0.3	W
Junction Temperature		$T_J$	150	$^\circ\text{C}$
Storage Temperature		$T_{STG}$	-55 to 150	$^\circ\text{C}$
Maximum Resistance - Junction to Ambient	$T_A=25^\circ\text{C}$	$I_S$	-1	A
Thermal Resistance- Junction to Ambient		$R_{\theta JA}^*$	150	$^\circ\text{C/W}$

Notes:

\* Surface Mounted on 1 in<sup>2</sup> pad area,  $t \leq 10$  sec

\*\* Pulse width  $\leq 300\mu\text{s}$ , duty cycle  $\leq 2\%$

## ELECTRICAL CHARACTERISTICS (T<sub>A</sub>=25°C)

Parameter	Symbol	Test Conditions	Min.	Typ.	Max.	Unit
<b>Static Characteristics</b>						
Drain-source Breakdown Voltage	V <sub>(BR)DSS</sub>	V <sub>GS</sub> =0V, I <sub>DS</sub> =-250μA	-20			V
Gate Threshold Voltage	V <sub>GS(th)</sub>	V <sub>DS</sub> =V <sub>GS</sub> , I <sub>DS</sub> =-250μA	-0.5		-1	V
Drain Leakage Current	I <sub>DSS</sub>	V <sub>DS</sub> =-16V, V <sub>GS</sub> =0V			-1	μA
Drain Leakage Current (T <sub>J</sub> =85°C)					-30	μA
Gate Leakage Current	I <sub>GSS</sub>	V <sub>GS</sub> =±8V, V <sub>DS</sub> =0V			±10	μA
On-State Resistance	R <sub>DS(on)</sub> <sup>a</sup>	V <sub>GS</sub> =-4.5V, I <sub>DS</sub> =-4A		30	37	mΩ
		V <sub>GS</sub> =-2.5V, I <sub>DS</sub> =-3A		42	52	mΩ
		V <sub>GS</sub> =-1.8V, I <sub>DS</sub> =-2A		57	72	mΩ
<b>Diode Characteristics</b>						
Diode Forward Voltage	V <sub>SD</sub> <sup>a</sup>	I <sub>SD</sub> =0.2A, V <sub>GS</sub> =0V	-0.5		-1.3	V
Reverse Recovery Time	t <sub>rr</sub>	I <sub>SD</sub> = -4A, dI <sub>SD</sub> /dt=100 A/μs		49.5		ns
Reverse Recovery Charge	Q <sub>rr</sub>			16.5		nC
<b>Dynamic Characteristics<sup>b</sup></b>						
Input capacitance	C <sub>iss</sub>	V <sub>GS</sub> =0V, V <sub>DS</sub> =-10V, Frequency = 1 MHz		1121		pF
Output capacitance	C <sub>oss</sub>			161		pF
Reverse transfer capacitance	C <sub>rss</sub>			148		pF
Turn-on Delay Time	t <sub>d(on)</sub>	V <sub>DS</sub> =-10V, V <sub>GEN</sub> =-4.5V R <sub>G</sub> =3.3Ω, R <sub>L</sub> =2.5Ω, I <sub>DS</sub> =-4A		5.5		ns
Turn-on Rise Time	t <sub>r</sub>			60.5		ns
Turn-Off Delay Time	t <sub>d(off)</sub>			89		ns
Turn-Off Fall Time	t <sub>f</sub>			73		ns
<b>Gate Charge Characteristics<sup>b</sup></b>						
Total Gate Charge	Q <sub>g</sub>	V <sub>GS</sub> =-4.5V, V <sub>DS</sub> =-10V, I <sub>DS</sub> =-4A		17.4		nC
Gate-Source Charge	Q <sub>gs</sub>			1.9		nC
Gate-Drain Charge	Q <sub>gd</sub>			4.1		nC

Notes:

a : Pulse test ; pulse width ≤ 300μs, duty cycle ≤ 2 %

b : Guaranteed by design, not subject to production testing

# PARAMETER CHARACTERISTIC CURVE

Figure1: Power Dissipation

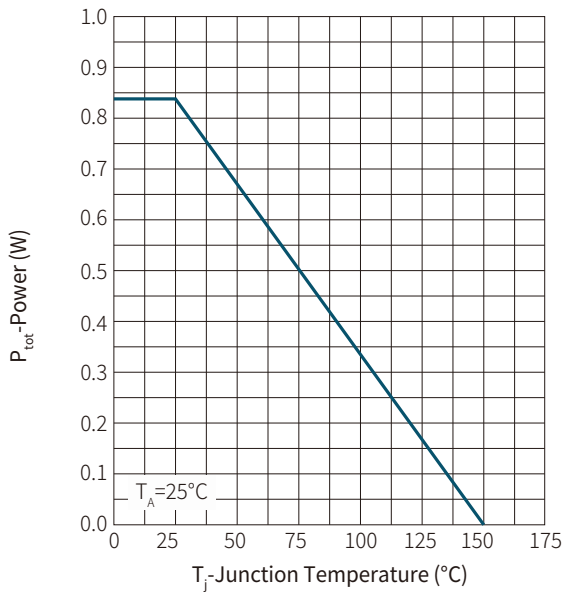

Figure2: Current Capability

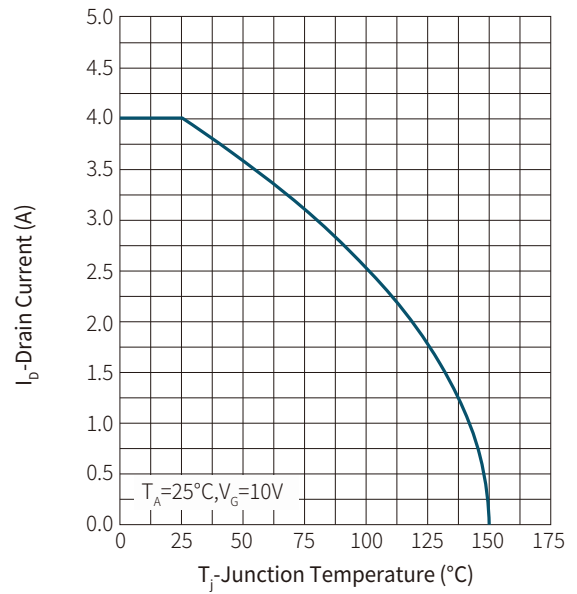

Figure3: Safe Operation Area

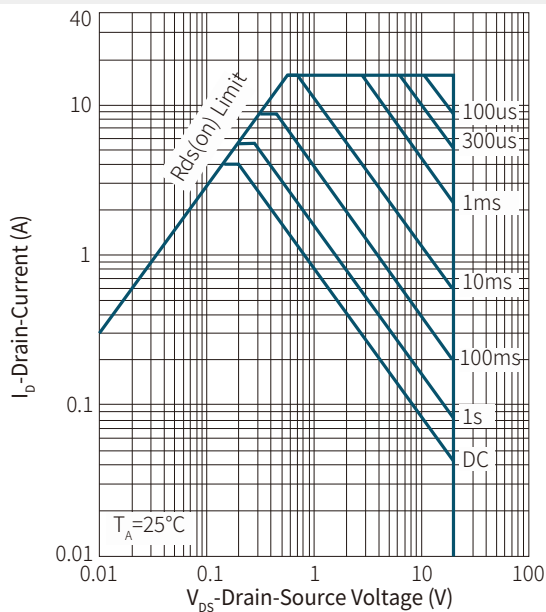

Figure 4: Transient Thermal Impedance

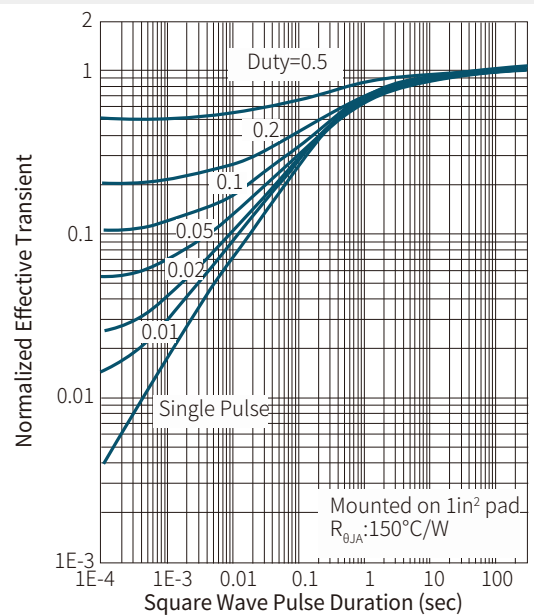

Figure 5: Output Characteristics

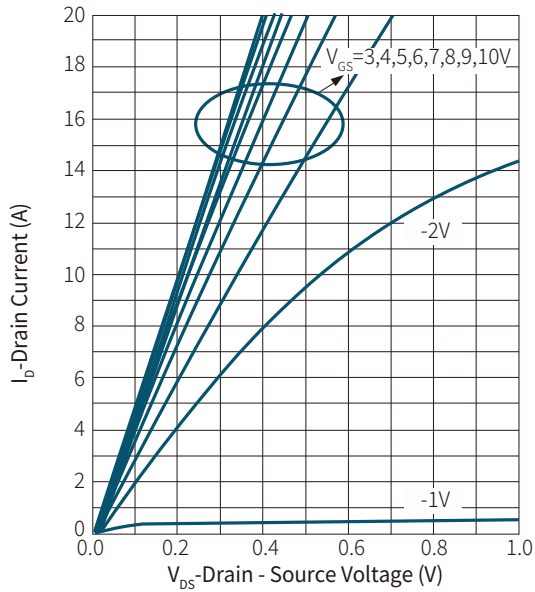

Figure 6: Drain-Source On Resistance

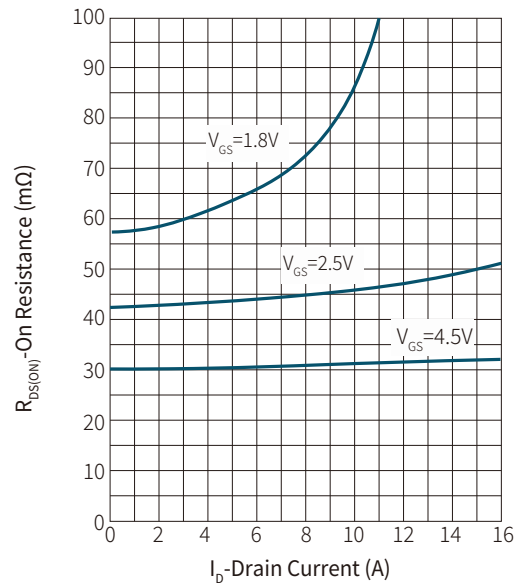

Figure 7: Transfer Characteristics

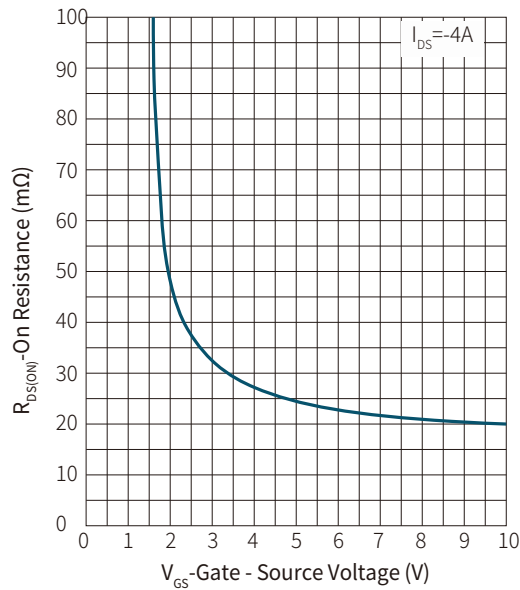
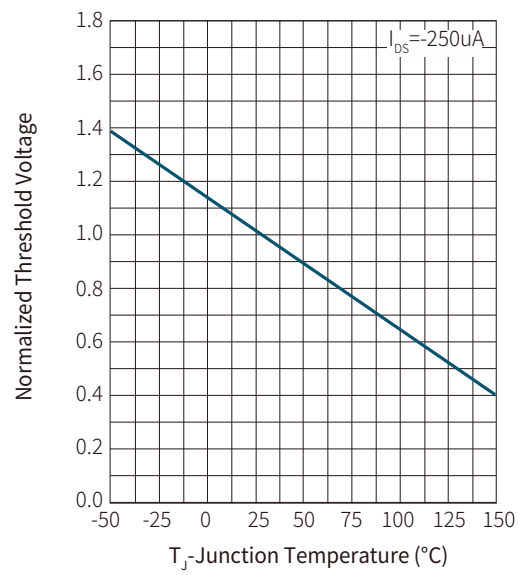
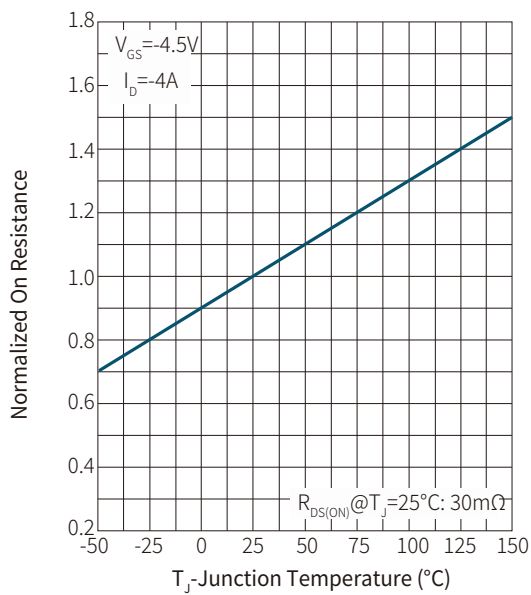
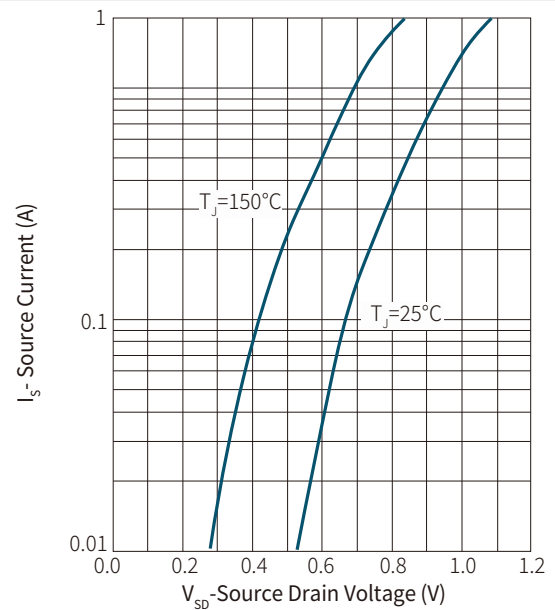
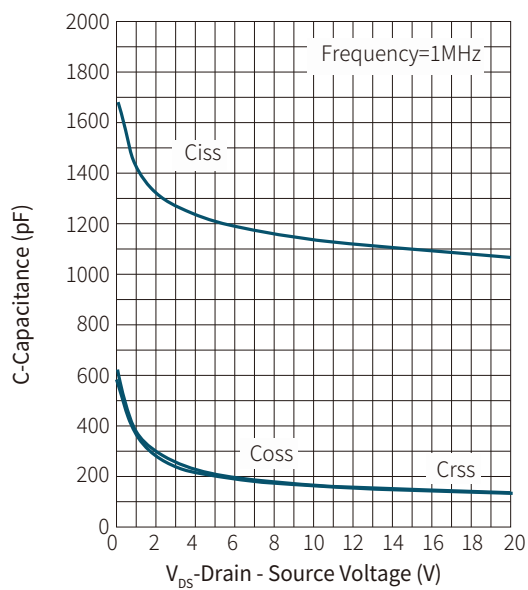
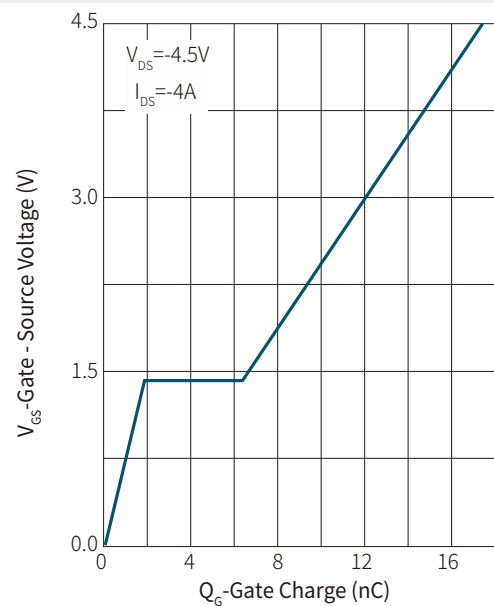
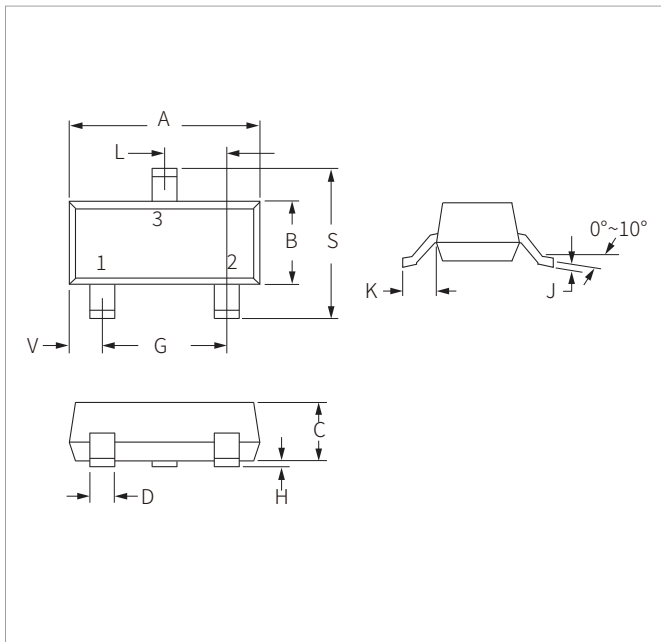

Figure 8: Normalized Threshold Voltage



**Figure 9: Normalized On Resistance**

**Figure 10: Current Diode Forward**

**Figure 11: Capacitance**

**Figure 12: Gate Charge**

## SOT-23 PACKAGE INFORMATION

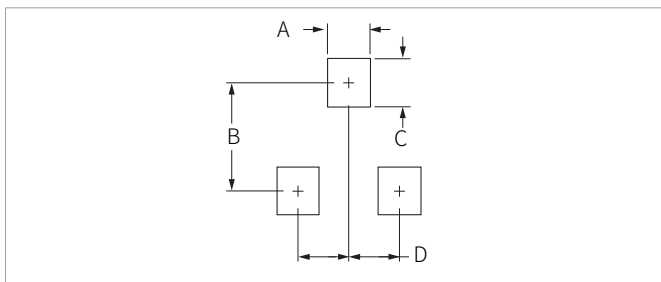

Ref.	Millimeters		Inches	
	Min.	Max.	Min.	Max.
A	2.80	3.04	0.110	0.120
B	1.20	1.40	0.047	0.055
C	0.89	1.11	0.035	0.044
D	0.37	0.50	0.015	0.020
G	1.78	2.04	0.070	0.081
H	0.01	0.100	0.001	0.004
J	0.085	0.180	0.003	0.007
K	0.35	0.69	0.014	0.029
L	0.89	1.02	0.035	0.040
S	2.10	2.64	0.083	0.104
V	0.45	0.60	0.018	0.024

## RECOMMENDED PAD LAYOUT DIMENSIONS



Ref.	Millimeters		Inches	
	Min.	Max.	Min.	Max.
A	0.71	0.97	0.028	0.038
B	1.88	2.13	0.074	0.084
C	0.71	0.97	0.028	0.038
D	0.81	1.07	0.032	0.042

## ORDERING INFORMATION

Part Number	Component Package	QTY/Reel	Reel Size
PM3415E	SOT-23	3000PCS	7"

To find your local partner within Semiwell' s website : [www.semiwell.com](http://www.semiwell.com)

© 2023 Semiwell Microelectronics Co.,Ltd.

The content of this document has been carefully checked and understood. However, neither Semiwell nor its subsidiaries assume any liability whatsoever for any errors or inaccuracies of this document and the consequences thereof. Published specifications are subject to change without notice. Product suitability for any area of application must ultimately be determined by the customer. In all cases, products must never be operated outside their published specifications. Semiwell does not guarantee the availability of all published products. This disclaimer shall be governed by substantive Chinese law and resulting disputes shall be settled by the courts at the place of business of Semiwell. Latest publications and a complete disclaimer can be downloaded from the Semiwell website. All trademarks recognized.