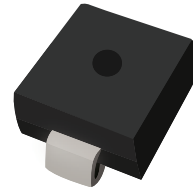


## FEATURES

- | Glass Passivated Die Construction
- | HI Power TVS Design in SMD package
- | 10000A Maximum Reverse Pulse Peak Current
- | Bi-Directional Versions Available
- | Innovative Automatic multi-layer pick and place assembly technology
- | Low clamping and slope resistance
- | 2nd level interconnectis Pd-free (IPC/JEDEC J-STD-609A.01)
- | Ideal for Automatic pick and place assembly



AKM



Schematic Symbol

## GENERAL INFORMATION

- | designed for use in high power DC Bus clamping applications
- | Available with standoff voltage rating 36V to 86V
- | compliant and meet IEC 61000-4-5 8/20us current surge requirements

## MECHANICAL DATA

- | Case : AKM,Molded plastic
- | Terminals : Solder plated, solderable

## APPROVALS

<b>RoHS</b>	Compliance with 2011/65/EU
<b>HF</b>	Compliance with IEC61249-2-21:2003

## MAXIMUM RATINGS ( $T_A=25^{\circ}\text{C}$ )

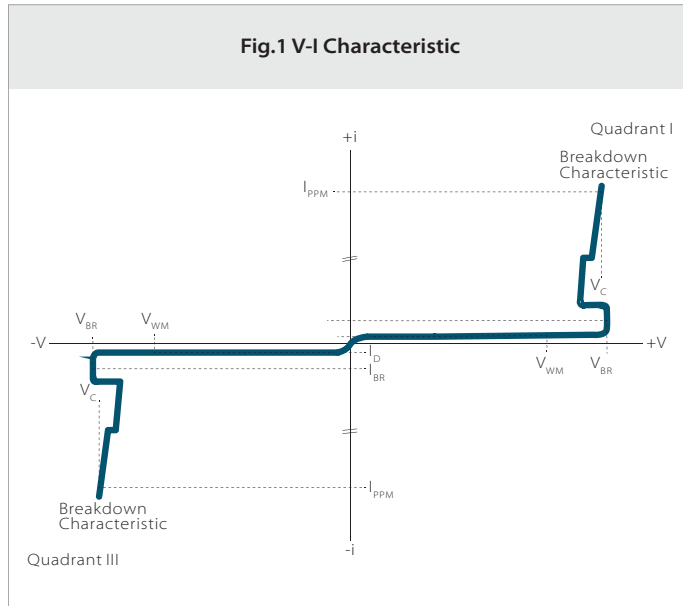
Parameter		Symbo	Value	Unit
Repetitive Standoff Voltage	AKM10-36C	$V_{WM}$	36	V
	AKM10-58C		58	
	AKM10-66C		66	
	AKM10-76C		76	
	AKM10-86C		86	
Peak Current Rating per 8/20 us IEC 61000-4-5		$I_{PPM}$	10000	A
Operating Junction Temperature Range		$T_J$	-55 to +125	$^{\circ}\text{C}$
Storage Temperature Range		$T_{STG}$	-55 to +125	$^{\circ}\text{C}$

## ELECTRICAL CHARACTERISTICS ( $T_A=25^{\circ}\text{C}$ )

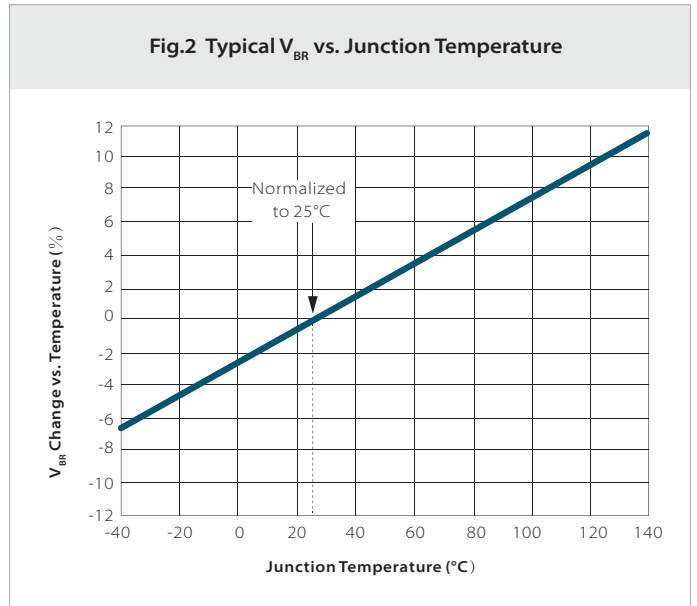
Part Number	Device Marking Code	Standoff Voltage ( $V_{WM}$ ) (V)	Max. Reverse Leakage ( $I_R$ ) @ $V_{WM}$ ( $\mu\text{A}$ )	Reverse Breakdown Voltage $V_{BR}@I_T$		Test Current $I_T$ (mA)	Max. Clamping Voltage $V_{CL}$ Peak Pulse Current ( $I_{PP}$ )				
				Min Volts	Max Volts		$V_{CL}$ Volts	$I_{PP}$ (8/20us) (A)		$I_{PP}$ (10/350us) (A)	
								Min.	Typ.	Min.	Typ.
AKM10-36C	AKM10-36C	36.0	10.0	39.0	46.0	10.0	98	10000	-	1400	-
AKM10-58C	AKM10-58C	58.0	10.0	64.0	70.0	10.0	110	10000	-	1400	-
AKM10-66C	AKM10-66C	66.0	10.0	72.0	80.0	10.0	120	10000	-	1400	-
AKM10-76C	AKM10-76C	76.0	10.0	85.0	95.0	10.0	140	10000	-	1400	-
AKM10-86C	AKM10-86C	86.0	10.0	95.0	105.0	10.0	157	10000	-	1400	-

# CHARACTERISTIC CURVES

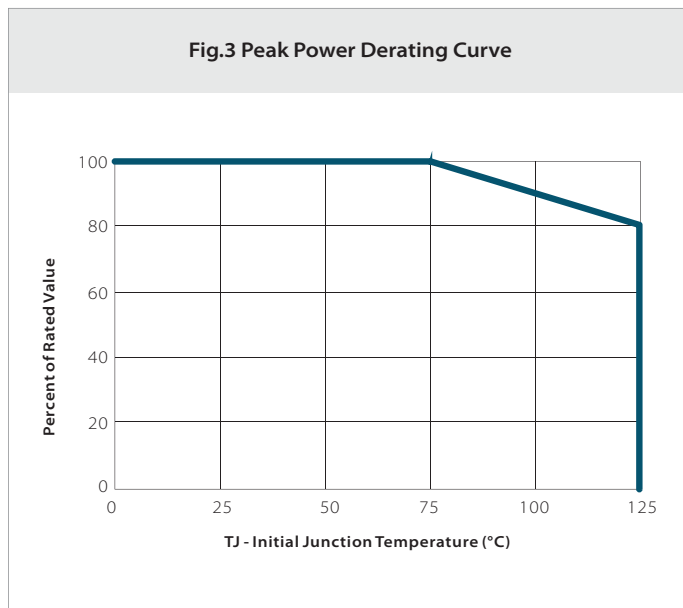
**Fig.1 V-I Characteristic**



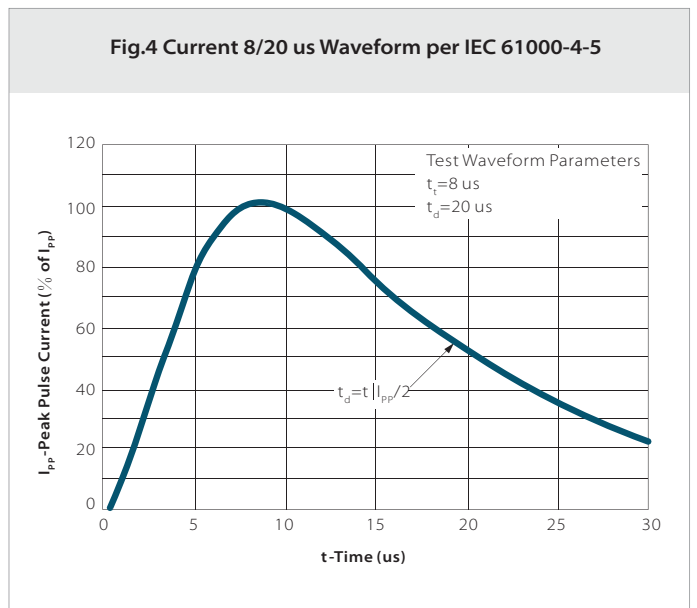
**Fig.2 Typical  $V_{BR}$  vs. Junction Temperature**



**Fig.3 Peak Power Derating Curve**

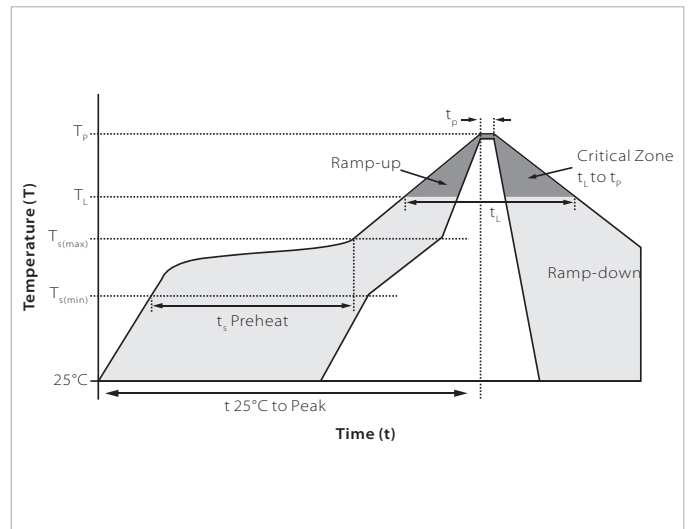


**Fig.4 Current 8/20 us Waveform per IEC 61000-4-5**

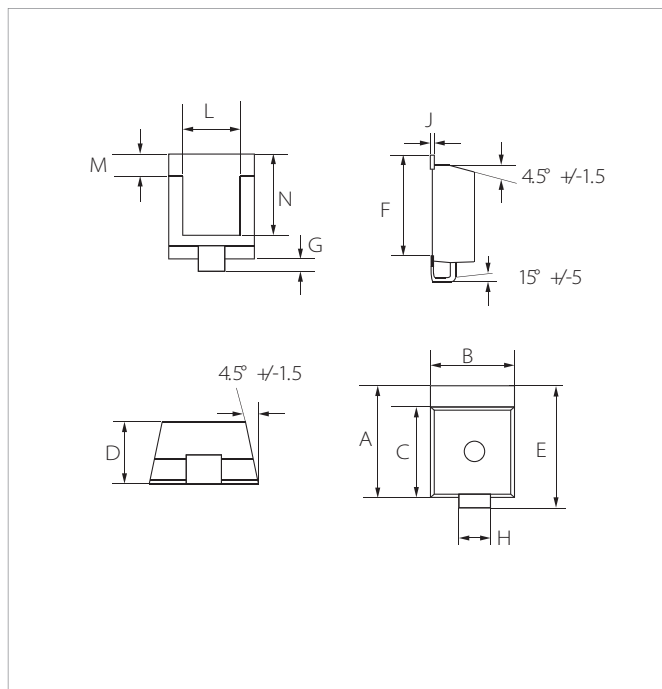


## SOLDERING PARAMETERS

Reflow Condition		Lead-free assembly
Pre Heat	Temperature Max ( $T_{s(min)}$ )	150°C
	Temperature Max ( $T_{s(max)}$ )	200°C
	Time (min to max) ( $t_s$ )	60 – 180 secs
Average ramp up rate (Liquidus Temp ( $T_L$ ) to peak)		3°C/second max
$T_{s(max)}$ to $T_L$ - Ramp-up Rate		3°C/second max
Reflow	Temperature ( $T_L$ ) (Liquidus)	217°C
	Time (min to max) ( $t_r$ )	60 – 150 seconds
Peak Temperature ( $T_p$ )		260°C
Time within 5°C of actual peak Temperature ( $t_p$ )		20 – 40 seconds
Ramp-down Rate		6°C/second max
Time 25°C to peak Temperature ( $T_p$ )		8 minutes max.
Do not exceed		260°C

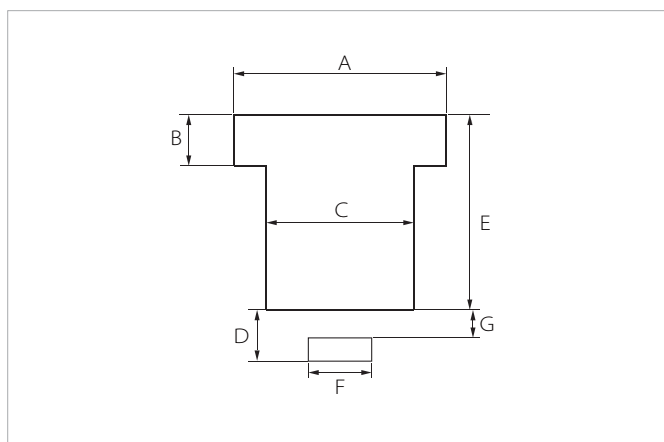


## AKM PACKAGE INFORMATION



Ref.	Millimeters		Inches	
	Min.	Max.	Min.	Max.
A	15.78	16.63	0.621	0.655
B	13.43	15.09	0.529	0.594
C	13.83	14.24	0.544	0.561
D	6.94	7.24	0.273	0.285
E	17.82	18.72	0.702	0.737
F	14.40	14.90	0.567	0.587
G	2.20	3.20	0.087	0.126
H	4.89	5.65	0.193	0.222
J	0.72	0.85	0.028	0.033
L	10.17	11.17	0.400	0.440
M	1.85	2.85	0.073	0.112
N	12.95	13.54	0.510	0.583

## RECOMMENDED PAD LAYOUT DIMENSIONS



Ref.	Millimeters	Inches
	Nominal	Nominal
A	13.50	0.540
B	2.50	0.100
C	10.62	0.425
D	4.77	0.191
E	13.25	0.530
F	5.25	0.210
G	0.125	0.005

## ORDERING INFORMATION

Part Number	Component Package	QTY/Reel	Reel Size
AKM10 Series	AKM	400PCS	13"

To find your local partner within Semiwell's website : [www.semiwell.com.cn](http://www.semiwell.com.cn)

© 2023 Semiwell Microelectronics Co.,Ltd.

The content of this document has been carefully checked and understood. However, neither Semiwell nor its subsidiaries assume any liability whatsoever for any errors or inaccuracies of this document and the consequences thereof. Published specifications are subject to change without notice. Product suitability for any area of application must ultimately be determined by the customer. In all cases, products must never be operated outside their published specifications. Semiwell does not guarantee the availability of all published products. This disclaimer shall be governed by substantive Chinese law and resulting disputes shall be settled by the courts at the place of business of Semiwell. Latest publications and a complete disclaimer can be downloaded from the Semiwell website. All trademarks recognized.